



PROEL GROUP BRAND

# ARS 1500

## SMOKE MACHINE

MANUALE UTENTE  
USER'S MANUAL



[sagitter.com](http://sagitter.com)

# ARS 1500

GENERATORE DI FUMO

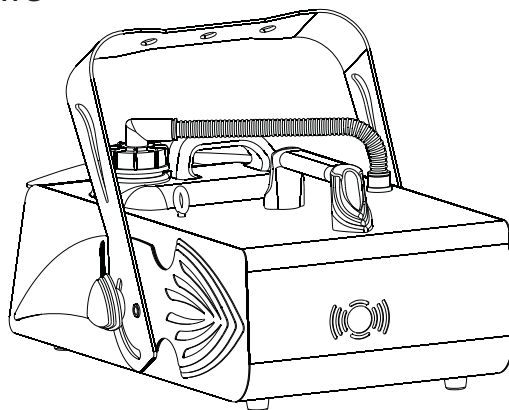

1. ARS1500 è un generatore effetto fumo di media capacità e dimensione.
2. Dispone di un connettore per il controllo tramite DMX-512 e di comando a distanza senza fili. Utilizza inoltre un sistema elettronico di controllo della temperatura. Il fumo diffuso dal generatore è completamente inodore.
3. Durante il funzionamento del generatore il controllo D-4 permette l'operatività a tempi e volumi fissi ma può anche essere utilizzato per regolare la quantità di fumo emesso.
4. Questo controllo può essere implementato in serie su 4 unità o su 4 gruppi, quando si utilizzano diversi generatori di fumo contemporaneamente.
5. Per evitare condensazioni di vapore occasionali, l'ugello del generatore monta un canale di assorbimento ad alta efficienza; inoltre, nel caso in cui il generatore venga appeso, esso eviterà che si verifichino sgocciolamenti.

ALIMENTAZIONE	220V - 240V 50 Hz 100V - 120V 60 Hz
RISCALDATORE	1500W
FUSIBILE	230V/8A 110V/15A
TEMPO DI RISCALDAMENTO INIZIALE	8 Min
VOLUME MASSIMO D'EMISSIONE	20000cu.ft/min
CAPACITA' SERBATOIO	3 LITERS
PESO	12 Kg
DIMENSIONI	602*360*275mm

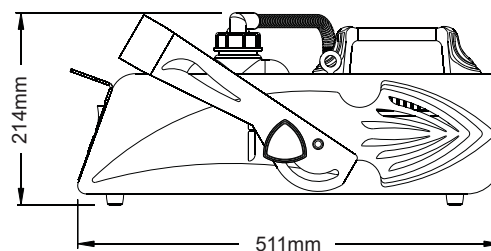

# FUNZIONI DEL PANNELLO D-4

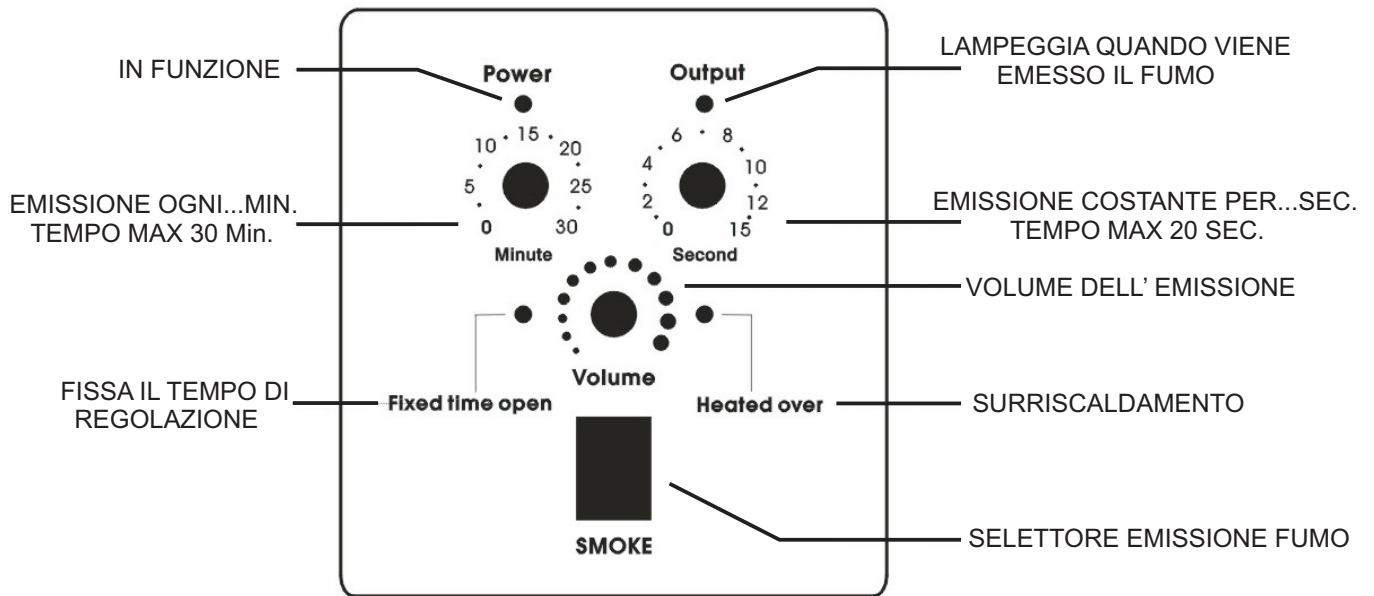

# ARS 1500

## SMOKE MACHINE

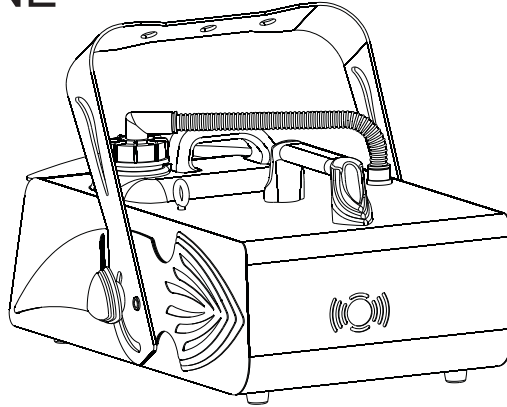

1. This is a durable smoke machine with middle amount of smoke output and cabinet volume.
2. This machine is equipped with the connector of wireless controlling and DMX-512 and also employed the electronic temperature control system. there is no peculiar smell in the sprayed smoke.
3. Meanwhile, the machine is employed the controller D-4 which can be worked in the fixed time with fixed quantity and also can adjust the amount of smoke output.
4. The selected controller may be employed in marshalling, by which you can control the machine with 4 units or 4 groups when several smoke machine are employed simultaneously.
5. In order to prevent the occasional hydrosphere condensation, the spout of the machine is installed the highly effective absorbing flume. Further more, there will be no water dripping when the machine is hung highly

POWER	220V - 240V 50 Hz 100V - 120V 60 Hz
HEATER	1500W
FUSE	230V/8A 110V/15A
FIRST HEAT UP TIME	8 Min
OUTPUT	20000cu.ft/min
TANK CAPACITY	3 LITERS
WEIGHT	12 Kg
DIMENSIONS	602*360*275mm

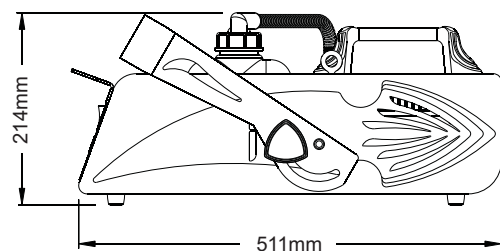

# FUNCTIONAL DIAGRAM OF D-4 TIMING CONTROLLER

