

LED Moving Head Light MJ-1006A

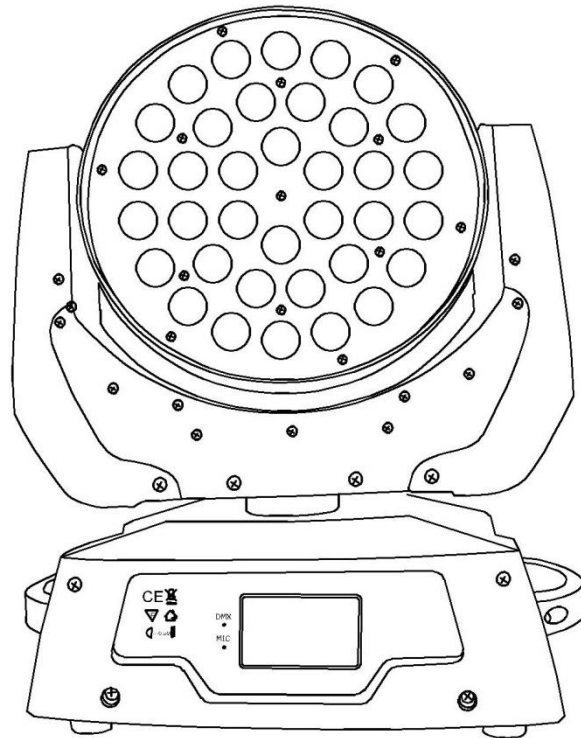

User manual

Thank you for choosing our LED moving head light. For the sake of your safety, Please read and follow these instructions carefully and keep this manual in a safe place for future reference.

Catalogue

Chapter	Page
Safe Usage Of The Product -----	3
Install The Equipment -----	4
Power Code Connection -----	4
DMX Connection -----	5
DMX Terminator -----	6
Function Set -----	6
Operation Menu -----	7
Maintenance -----	9
Keeping The Product Clean -----	10
Trouble Shooting-----	10
Equipment and Appendix-----	10
Channel List-----	11
Technical Parameters-----	12

☆Important notice:

- In this instruction for use contains about the installment and the use aspect important information of the LED moving head. When installing and using, you need to look this usage instruction strictly.
- Before open the LED moving head and if you want to do the repair work, please make sure the power source is at the separation condition.
- Every unit is tested completely and packed properly by the manufacturer. Please make sure the packing and the unit are in good condition before installation and use. Should there be any damage caused by transportation, consult your dealer and do not use the unit. Any damage caused by improper use will not be assumed by the manufacturer or dealer.

Attention: Unceasingly carries on the product improvement about our company the policy, in this instruction booklet carries the data will have the possibility to be able to change in the future, when no longer separate notice change matters concerned. Our company retains when the product improvement changes the related specification the authority. This instruction booklet publisher cannot be responsible regarding this instruction booklet in information accuracy, also cannot the related consequence which causes regarding these information be responsible.

SAFE USAGE OF THE PRODUCT



When unpacking and before disposing of the carton, check there is no transportation damage before using the product. Should there be any damage caused by transportation, consult your dealer and do not use the apparatus.

The product is for indoor use only, IP20. Use only in dry locations. Keep this device away from rain and moisture, excessive heat, humidity and dust. Do not allow contact with water or any other liquids.

The product is not designed or intended to be mounted directly on to inflammable surfaces

The product is only intended for installation, operation and maintenance by professional person.

The product must be installed in a location with adequate ventilation, at least 50cm from adjacent wall surfaces. Be sure that no ventilation slots are blocked.

Do not project the beam onto inflammable surfaces, minimum distance is 5m.  5m 

Avoid direct exposure to the light from the lamp. The light is harmful to the eye.

Do not attempt to dismantle or modify the projector in any way.

Electrical connection must only be carried out by qualified personnel.

Before installation, ensure that the voltage and frequency of power supply match the power requirements of the projector.



It is essential that each projector is correctly earthed and that electrical installation conforms to all relevant standards.

Do not connect this device to any other types of dimmer apparatus.

Make sure that the power-cord is never crimped or damaged by sharp edges. Never let the power-cord come into contact with other cables. Only handle the power-cord by the plug. Never pull out the plug by tugging the power-cord.

Keep the optical system clean. Do not touch the LED lens with bare hands.

The product should always be installed with a secondary safety fixing. On the projector base brink, there is a hole for the safety cord provided. It should be attached as shown in “installing the projector” section.

LED lens shall be changed if they have become visibly damaged to such an extent that their effectiveness is impaired, for example by cracks or deep scratches.  

Exterior surface temperatures of the luminaire after 5 minutes operation is 40 °C, when steady state is achieved 50 °C.

There is no user serviceable parts inside the projector, do not open the housing and never operate the product with the covers removed.

If you have any questions, don't hesitate to consult your dealer or manufacturer.

★Always disconnect from the mains, when the device is not in use or before cleaning it or before attempting any maintenance work !

Install The Equipment:

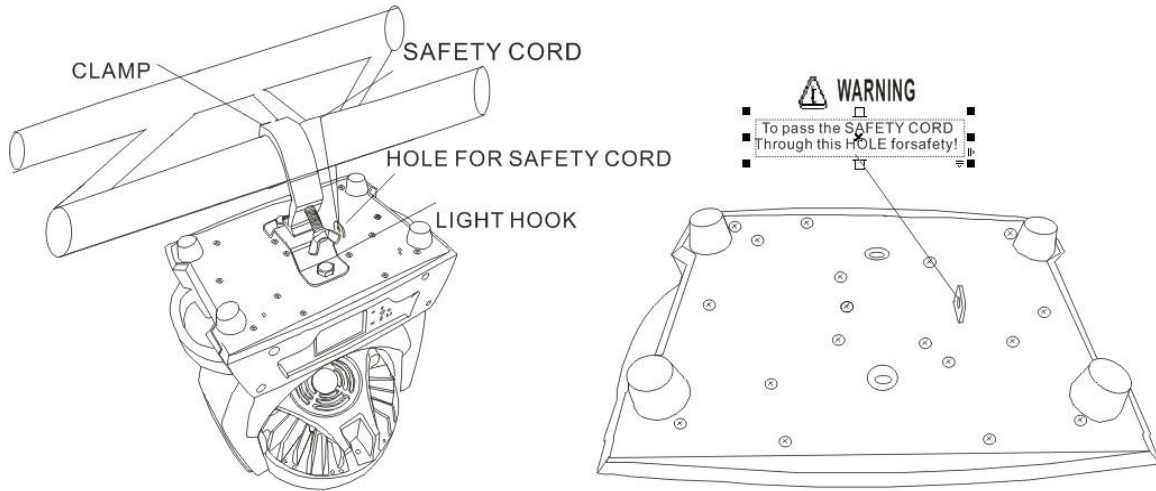

Use 1pcs clamp and safety cord(need to purchase).Use clamp fix with light hook which in the packing box with light, then use screw install to the bottom of lamp. Hang the fixture on the structure and fasten the screws attached to each clamp. Make sure the light is installed reliable, and confirm the light which you fixed is strong enough for hanging the light. Base on safety reason, please according to the above picture using safety wire cross the light to make it strong enough again.

Warning!

1. Hook and clamp only use for hanging the light. Do not use clamp as a tool to move fixtures.
2. Base on safety reason, please use the safety cord which can afford the weight ten times of lamp through Insurance hole for auxiliary hanging.
3. Don't use the handle of the moving head light to fixed or lift!

Power Code Connection:

Connect the power cord as follows:

L (live) =brown

E (earth) =yellow/green

N (neutral) =blue

Use the plug provided to connect the mains power to the projector paying attention to the voltage and frequency marked on the panel of the projector. It is recommended that each projector be supplied separately so that they may be individually switched on and off.

★It is essential that each projector is correctly earthed and the electrical installation conforms to all relevant standards.

DMX Connection:

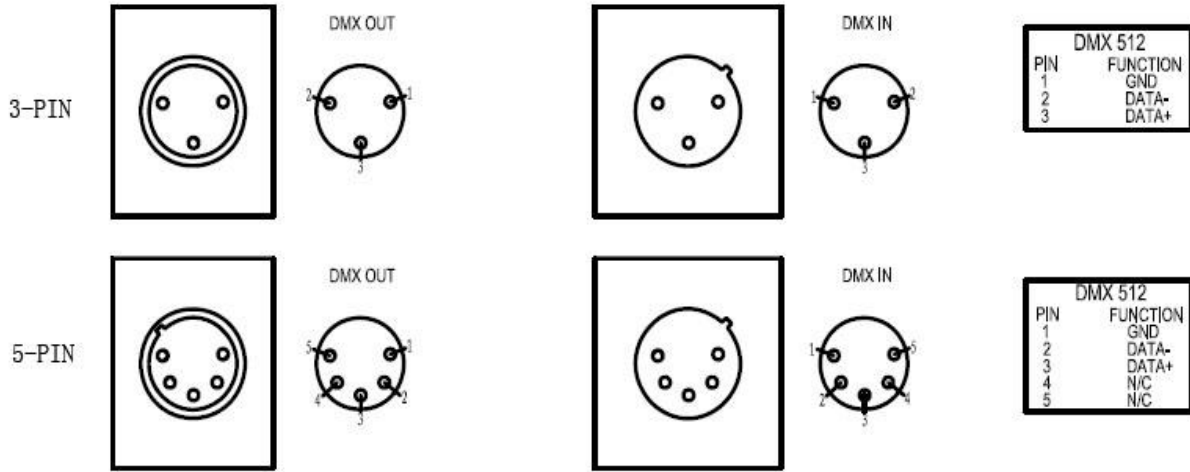

Connection between the controller and a projector and between one projector and another must be made with a 2 core-screened cable, with each core having at least a 0.5mm diameter. Connection to and from the projector is via cannon 3 pin (which are included with the projector) XLR plugs and sockets. The XLR's are connected as shown in the figure above.

Note: Care should be taken to ensure that none of the pins touch the metallic body of the plug or each other. The body of the plug is not connected in any way. The XLED 590 accepts digital control signals in protocol DMX512 (1990).

Connect the controller's output to the first fixture's input, and connect the first fixture's output to the second fixture's input and connect the rest fixtures in the same way. Eventually connect the last fixture's output to a DMX terminator as shown in the figure below.

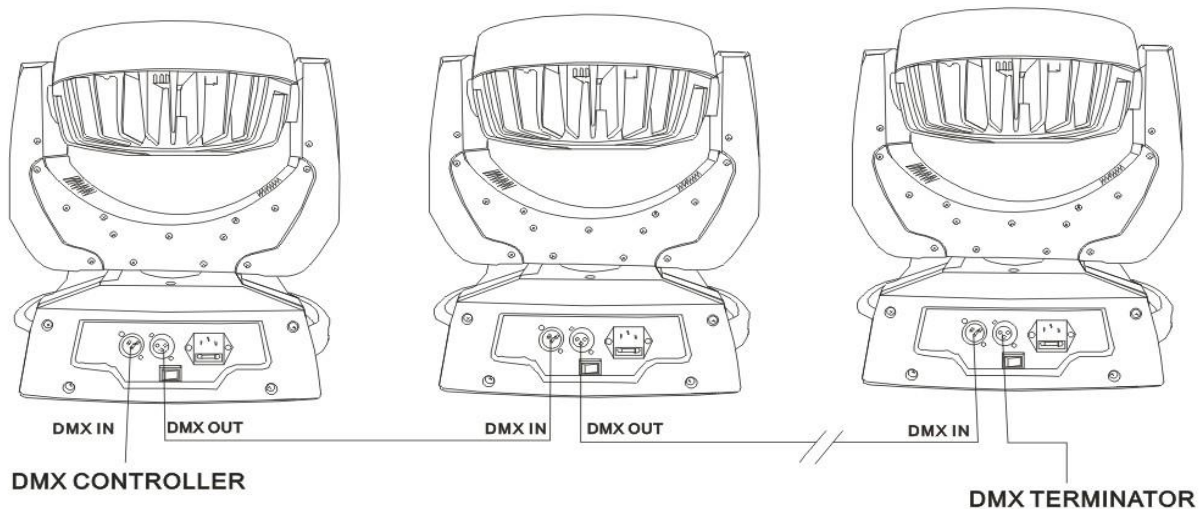

DMX Terminator:

In the Controller mode, at the last fixture in the chain, the DMX output has to be connected with a DMX terminator. This prevents electrical noise from disturbing and corrupting the DMX control signals.

The DMX terminator is simply an XLR connector with a 120Ω (ohm) resistor connected across pins 2 and 3, which is then plugged into the output socket on the last projector in the chain. The connections are illustrated below.

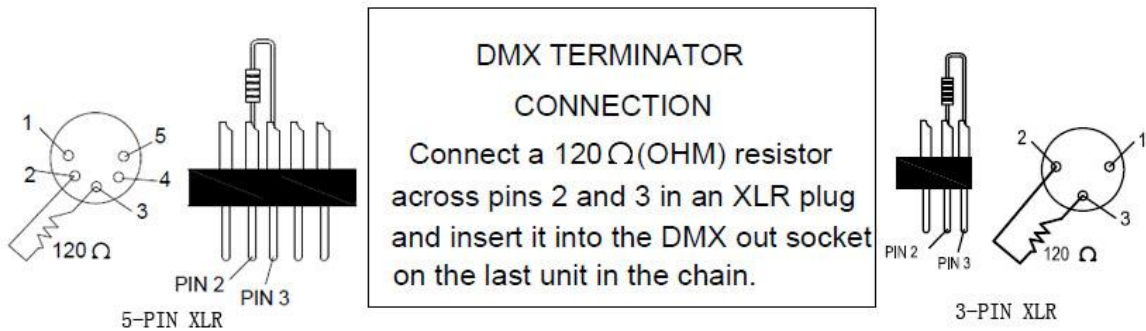

Function Set:

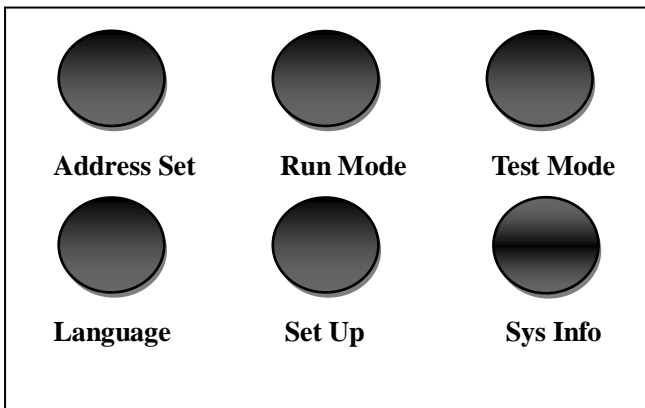

Picture 1

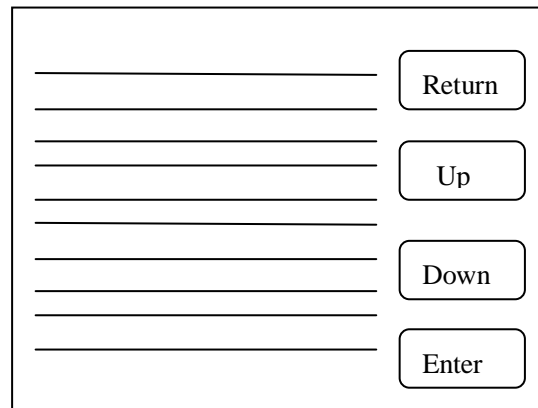

picture 2

Touch LCD into the main menu, when the LCD is off.

When the LCD display the main menu,touch the menu into sub menu.(as picture 1)

Use button switch and LCD display, can set the address code and function code easily.

Check or modify lighting function settings, Touching the LCD display panel. LCD display panel will display function menu of lighting. Function operation menu all have corresponding submenu(as picture 2) . Each menu all represent the specific functions of lamps, specific see below "operation menu" section.

Set or browse function setting of lamp, touch UP or DOWN key.

Touch **ENTER** key to save your changes or to **ENTER** submenu, Touch **UP** or **DOWN** can change value(Plus or reduce number).

According to the **Return** key to return to the last menu.

Operation Menu:

➤ Menu Structure chart

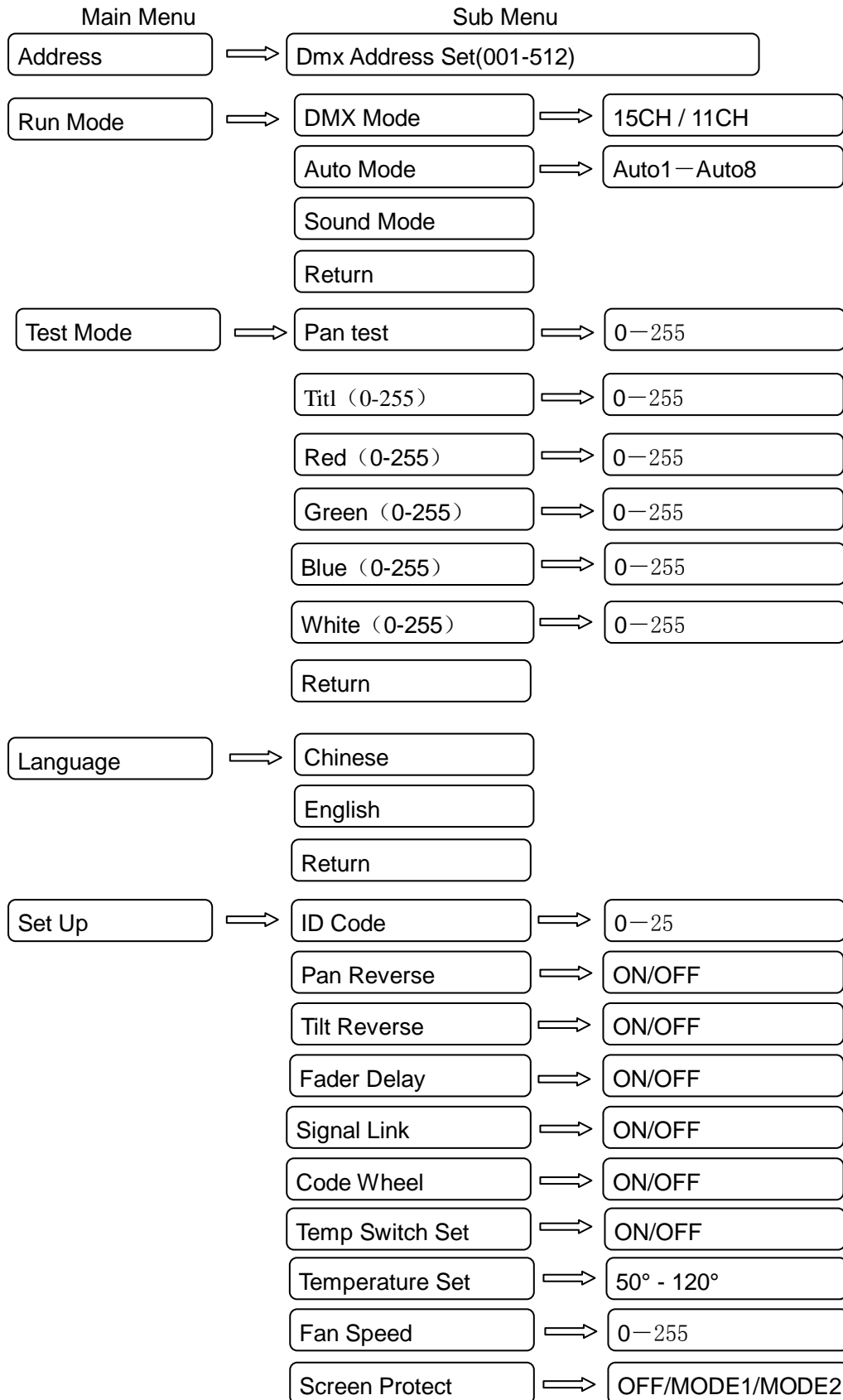

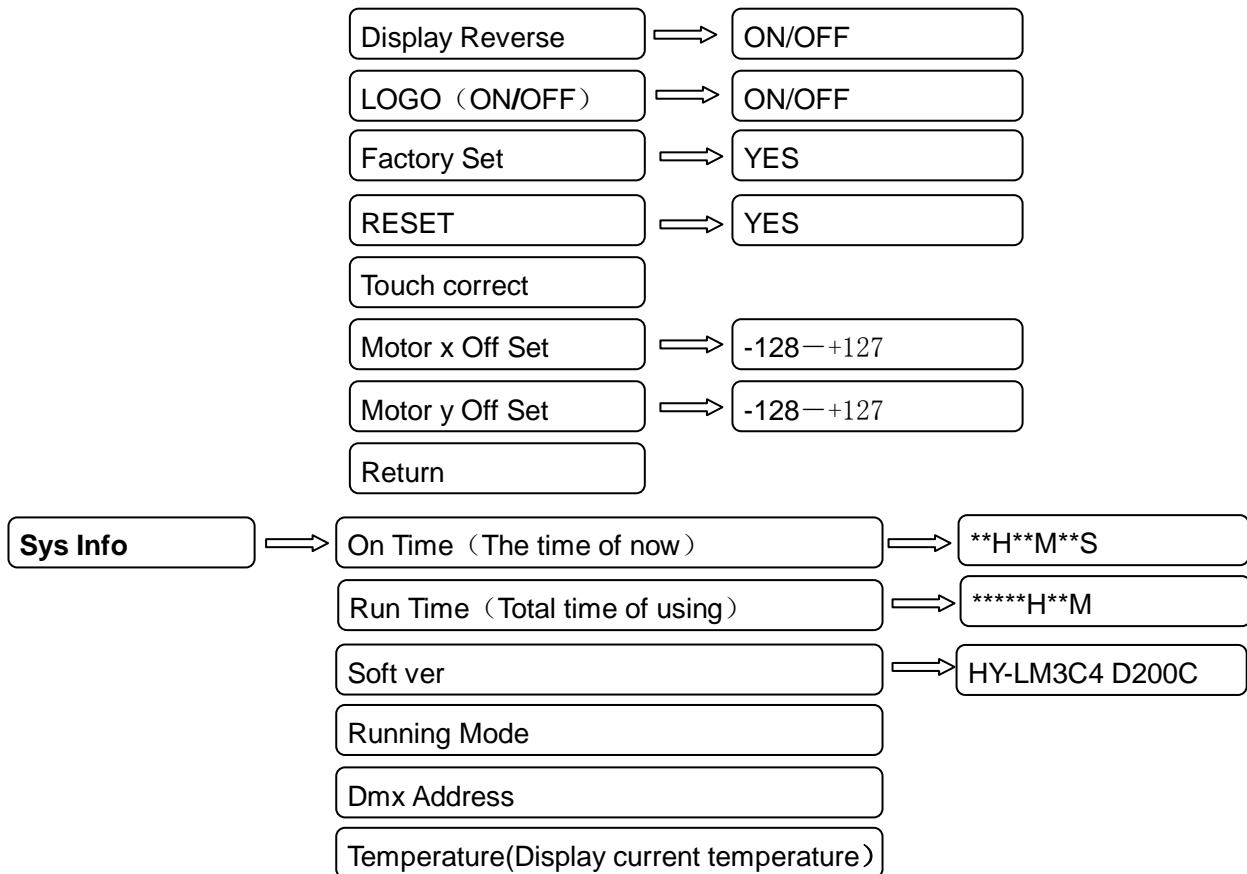

➤ **Main Menu**

Touch the menu to into setting.

➤ **Sub Menu**

Sub menu include address, run mode, test mode, language , Setup and sys info. Touch the main menu picture to do each setting.

- 1) **Address setting**, after you finished the setting, then you need to touch “ ENTER” button to keep the address code and return to main menu.
- 2) **Run mode**, “√” is mean to the currently run mode. At the same time, only running one mode. When you select DMX mode and auto mode, touch “ ENTER”, also can choose different DMX mode and auto mode.
 - When the light in the DMX mode, then also can be slave mode. If the light connect to the DMX control signal, then it is DMX mode. If you connect the light is Master signal, then it is running slave mode.
 - Auto mode, auto mode also can be master mode.
 - When the light in sound mode, it can’t be master mode.
- 3) **Test mode**, test mode is a special mode, only can be used when it is in test mode interface, exit interface, then return to previous running mode. In the test mode, you can adjust Pan, tilt and focus motor’s position, also can adjust intensity of RGBW color. The RGBW color of test mode can be used by the 16th channel in the DMX mode.
- 4) **Language**, menu language can choose Chinese or English.
- 5) **Setup**,
 - ID code, ID code is using for DMX mode in the channel16th, when the value of channel 16th

over number 9, only ID code corresponding to the front two value which in 16th channel, then other channel value are available now.

- Pan reverse set
 - Tilt reverse set
 - Handspike delay, when switch on handspike delay, the controller handspike can achieve soft dimming effect. Handspike delay can be chosen ON/OFF on the controller.
 - Signal link: When turn on signal link, cut off control signal will be blackout.
 - Code wheel: If off, ID code will failure in reset and running mode, can't record correct position of pan and tilt. Will recover from wrong running operation. Reset can be max travel reset from code wheel reset.
 - Temp Switch: Temperature protect switch.
 - Temperature: Protect temperature, when start temp protect function, if test temperature over protect temperature, then brightness will be reduce a half.
 - Fan speed: keep
 - Screen protect: It can be set turn off, mode 1 and mode 2. When it's OFF, then won't enter screen protect condition. When in mode 1, it will clear the screen. When in mode 2, after you into screen protection, big letter display current address code. Touch the screen, you can exit screen protect condition, and return main menu.
 - Screen Rot: this menu can let the screen inversion 180 degree.
 - Logo: if display logo
 - Factory set: you can set all parameters to factory set.
 - Reset: reset
 - Touch correct: When display have excursion with touch screen, you can recalibration.
- 6) **Sys info** : display related information on system
- ON time: The current time when you power on it
 - Run time: Total time of using this light
 - Ver: current version of software
 - Running mode: System running mode currently
 - DMX address
 - Temperature: Display current temperature

Control panel of LED display information:

Green	On	DMX signal OK
	Off	No DMX signal
	Flash	DMX signal error
Red	On	Power

Maintenance:

To prolong the life of the projector, some maintenance work has to be done to ensure the LED optical system in good condition. If the projector does not function, check the fuses on the power socket of the projector, they should only be replaced by fuses of the same specification. Should

these be damaged, call a qualified technician before replacement. The projector has thermal protection device that will switch off the projector in case of overheating. Should either of these operate, check that the fans are not blocked, and if they are dirty, clean them before switching on the projector again. Check that the fans are operational, if not, call a qualified technician.

☆Any maintenance work should only be carried out by qualified technicians.

Keeping The Product Clean:

To ensure the reliability of the projector, it should be kept clean. It is recommended that the fans should be cleaned every 15 days. LED lens should also be regularly cleaned to maintain an optimum light output.

Cleaning frequency depends on the environment in which the fixture operates: damp, smoke or particularly dirty surroundings can cause greater accumulation of dirt on the unit's optics. A soft cloth and typical glass cleaning products should be used for cleaning. It is recommended to clean the external optics at least once every 15 days.

☆Do not use any organic solvent, e.g. alcohol, to clean housing of the apparatus.

Trouble Shooting:

Problem	Answer
The LED moving head light doesn't switch on.	Check the fuse the power socket
Although shines, but the LED moving head lamp doesn't accept the instruction of the controller.	Check the digital start address and also check the connection situation of the communication control line
LED moving head lamp only can work intermittently.	Inspect the power supply and voltage is whether normal.
Do not receive the DMX512 signal.	Whether the signal lines do contact well or broken.
The light beam appears gloomily.	Check that the heat dissipation system is running normally or Inspect the optics part is whether clean.

☆Other maintain work should by the specialist which has the experience to carry on.

Equipment and Appendix:

The packing list of this light as follows:

- ☆ Led moving head light 1pcs
- ☆ Power Cable 1pcs
- ☆ Signal Cable 1pcs
- ☆ Light Hook 1pcs
- ☆ M10 Screw 2pcs
- ☆ The Product of Instruction 1pcs

Channel List:

15CH MODE

Channel	Value	Control function
1	0-255	Main dimming ON
2	0-255	Red
3	0-255	Green
4	0-255	Blue
5	0-255	White
6	0-255	User customs color
7	0-255	Pan
8	0-255	Tilt
9	0-255	Pan fine (16Bit)
10	0-255	Tilt fine (16Bit)
11	0-255	XY motor speed from quick to slow
12	0	No strobe
	1-255	Strobe from slow to quick
13	0	No marco funtion
	1~25	Start controller handspike
	26-50	Turn off controller handspike
	51-90	Program color selection switch
	91-130	Pulse change
	131-170	Jump change
	171-210	fade
	211-250	Inside mode 1 (can't be controlled)
	251-255	Sound mode (can't be controlled)
14	0-255	pulse, jump, fade from slow to quick (CH14 is 91-210 之间)
	0	Can't use color selection function
	1~20	R255 G↑ B0 W0
	21~40	R↓ G255 B0 W0
	41~60	R0 G255 B↑ W0
	61~80	R0 G↓ B255 W0
	81-100	R↑ G0 B255 W0
	101-120	R255 G0 B↓ W0
	121-140	R255 G↑ B↑ W0
	141-160	R↓ G↓ B255 W0
	161-170	R255 G255 B255 W255
	171-200	R0 G0 B0 W0
	201-205	R242 G204 B5 W227
	206-210	R242 G215 B5 W227
	211-215	R255 G255 B50 W255
	216-220	R255 G255 B90 W255
	221-225	R255 G255 B118 W255
	226-230	R255 G255 B132 W255
	231-235	R255 G255 B151 W255
	236-240	R255 G255 B171 W255
241-245	R255 G255 B185 W255	

15	246-250	R255 G255 B197 W255
	251-255	R255 G255 B234 W255
	0-9	IDcode fail
	10-19	ID1
	20-29	ID2
	30-39	ID3
	40-49	ID4
	50-59	ID5
	60-69	ID6
	70-79	ID7
	80-89	ID8
	90-99	ID9
	100-109	ID10
	110-119	ID11
	120-129	ID12
	130-139	ID13
	140-149	ID14
	150-159	ID15
	160-169	ID16
	170-179	ID17
	180-189	ID18
	190-199	ID19
	200-209	ID20
	210-219	ID21
	220-229	ID22
230-239	ID23	
240-249	ID24	
250-255	ID25	

11CH MODE

Channel	Value	Control function
1	0-255	Main dimming
2	0-255	Red
3	0-255	Green
4	0-255	Blue
5	0-255	White
6	0-255	User customs color
7	0-255	Pan
8	0-255	Tilt
9	0-255	Pan fine (16Bit)
10	0-255	Tilt fine (16Bit)
11	0-255	XYmotor speed from quick to slow

Technical Parameters:

Construction: Composite plastic, die-casting aluminum,

Voltage: AC90V-240V; 50/60Hz

Power Consumption: 420W (220V)

LED Bulbs: 4IN1*36LEDs

LED Current: 500mA

LED Lifetime: 50000Hours

Colors: RGBW color mixing

Adjusts the light: 0-100 electron adjusts the light, various colors may alone move also may mix the color tone

Strobe: 1-25/second high speed strobe, but single color Mixes the color strobe

Head Movement: Pan 630°, Tilt 270°, with auto position correction and electronic replacement function.

Beam Angle: 25°

Control mode: DMX 512, Stand –alone mode, Self-test mode, Sound, Master/slave

DMX Channel: 11CH, 15CH

Control Panel: LCD display panel

IP Grade: IP20

Work Environment Temperature: -20 °C~40 °C

Other Functions: Pan and Tilt speed adjustable; Fan automatic control function; Display LED lamps and lanterns use time; Menu inversion, Screen protection, Touch correct

Net weight: 10KG

Gross Weight: 12 kg

Package Size: 420 x 330x 460cm

Light Size(see it below)

